

Assessment Test for Singapore Primary Mathematics 5B Common Core Edition

This test covers material taught in Primary Mathematics 5B Common Core Edition
(<http://www.singaporemath.com/>)

1. Consider the number 12.406
- (a) What is the value of the digit in the tenths place? _____ [1]
- (b) What digit is in the hundredths place? _____ [1]
- (c) What is difference between this number and 12.4? _____ [1]
- (d) Fill in the blanks with a whole number or a fraction. [1]

$$12.406 = 1 \times \underline{\quad} + 2 \times \underline{\quad} + 4 \times \underline{\quad} + 6 \times \underline{\quad}$$

2. Write $>$, $<$, or $=$ in each \bigcirc
- (a) $0.205 \bigcirc \frac{25}{1000}$ (b) $4.10 \bigcirc 4.1$ [2]
- (c) $3.1 - 0.46 \bigcirc 2 + 0.06$ (d) $0.89 \times 7 \bigcirc 7$ [2]
- (e) $17.4 \div 5 \bigcirc \frac{3}{10}$ (f) $3 - 0.12 \bigcirc 2\frac{8}{9}$ [2]

3. Multiply or divide. Use mental calculation.
- (a) $0.4 \times 100 = \underline{\quad}$ (b) $0.008 \times 1,000 = \underline{\quad}$ [2]
- (c) $56.8 \div 100 = \underline{\quad}$ (d) $0.007 \div 0.01 = \underline{\quad}$ [2]
- (e) $400 \times 0.8 = \underline{\quad}$ (f) $120 \div 0.02 = \underline{\quad}$ [2]

4. Find the equivalent measures.

(a) $0.04 \text{ m} = \underline{\hspace{2cm}} \text{ cm}$

(b) $6.25 \text{ lb} = \underline{\hspace{1cm}} \text{ lb } \underline{\hspace{1cm}} \text{ oz}$ [2]

(c) $35 \text{ ml} = \underline{\hspace{2cm}} \text{ liters}$

(d) $0.75 \text{ ft} = \underline{\hspace{2cm}} \text{ in.}$ [2]

5. Multiply or divide. Give an estimate first.

(a) 17.02×43

(b) 8.1×2.19 [4]

Estimate:

Estimate:

Answer:

Answer:

(c) $11.25 \div 18$

(d) $89.96 \div 0.04$ [4]

Estimate:

Estimate:

Answer:

Answer:

6. Find the following correct to 2 decimal places

(a) $49.95 \div 0.07$

(b) $89.5 \div 31$

[4]

7. The total cost of 4 lb of fish and 3 lb of meat is \$42.40. If 1 lb of fish costs \$3.25 more than 1 lb of meat, what is the cost of 1 lb of meat? [3]

8. The length of one side of a cube is 1 yd. What is its volume in cubic feet? [2]

9. Find the volume the rectangular prism and cube.

(a)

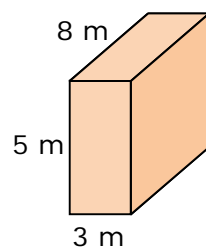

(b)

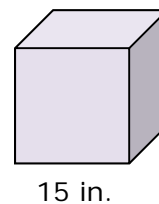

[2]

10. The following figure is made from centimeter cubes. Find the volume. [3]

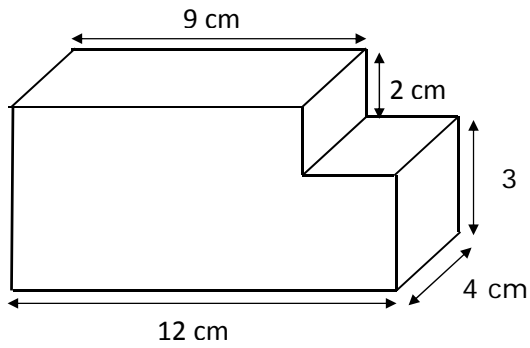

11. The area of one side of a rectangular prism is 72 cm^2 , and its volume is 360 cm^3 . What is the length of the unknown edge?

$AB =$

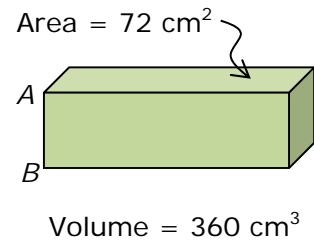

12. A rectangular tank measuring 25 cm by 16 cm by 26 cm is to be filled with water to a depth of 18 cm. How much more water is needed to fill the tank? Give your answer in liters. (1 liter = 1000 cm^3)

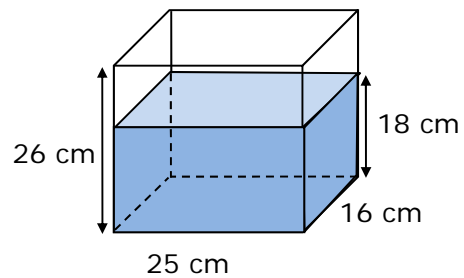

13.	How many 4-cm cubes can fit into a rectangular box 1 m long, 0.4 m wide, and 0.6 m high?	[3]
14.	A rectangular container 8 cm long and 9 cm wide was filled with water to a depth of 6 cm. When 12 marbles of equal size were added to the container, the depth of the water became 7.5 cm. Find the volume of one marble.	[3]
15.	Find the average of 21.4, 18.2, and 65.7.	[2]
16.	Fill in the blank: The average of 42, 36, _____, and 25 is 30.	[2]
17.	The average weight of 3 packages is 2 kg 750 g. The average weight of 2 of them is 3 kg 200 g. Find the weight of the third package. Give your answer in kg and g.	[2]

18. Valerie recorded the weights of some mature dogs of a certain small breed that were brought to the veterinarian clinic to the nearest quarter of a pound.

Weight in pounds

5	$5\frac{3}{4}$	$3\frac{3}{4}$	$5\frac{1}{2}$	5
6	$6\frac{1}{4}$	$4\frac{1}{2}$	$5\frac{3}{4}$	$5\frac{1}{2}$
$5\frac{1}{4}$	$6\frac{1}{2}$	6	$4\frac{3}{4}$	$5\frac{1}{2}$

- (a) Create a line plot from the data. [2]

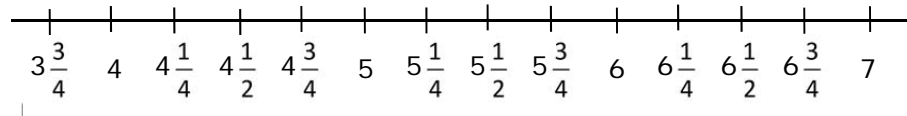

- (b) What is the difference between the heaviest and lightest weight recorded? [1]

- (c) What fraction of the dogs weigh the most common weight recorded? [1]

- (d) What is the average of the data? [2]

19.

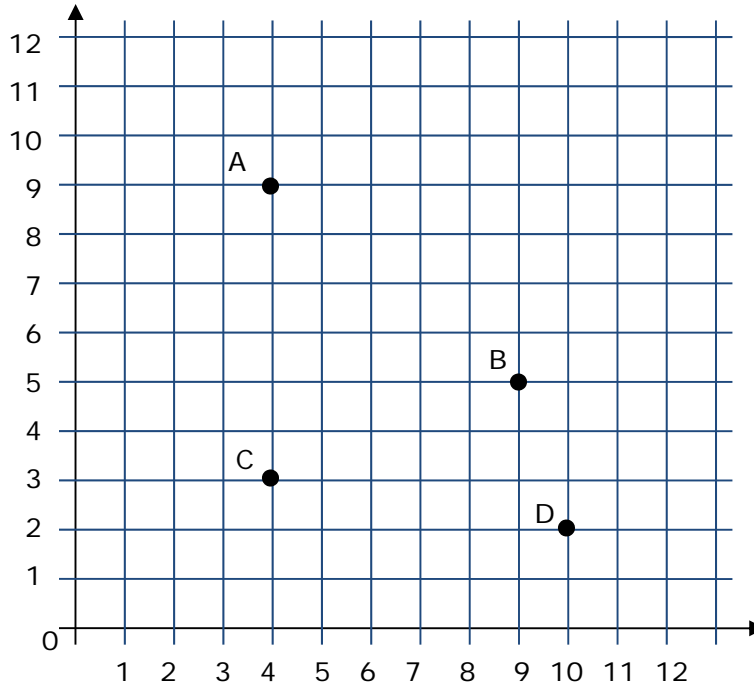

(a) Write the ordered pair for each of the points. [2]

A: _____ B: _____

C: _____ D: _____

(b) Draw a point at (6, 10). [1]

(c) Which coordinates, the first or the second, of the ordered pairs do you subtract to find the distance between A and C? [1]

20. A rectangle has coordinates (4, 3), (4, 10), (10, 10), and (10, 3) on a grid with 1 centimeter squares. What is area of the rectangle? [2]

21. (a) In Sequence A, each number is obtained by adding 2 to the previous number. Complete the table. [1]

Term (x)	1	2	3	4	5
Number (y)	2	4			
(x, y)	(1, 2)	(2, 4)			

- (a) In Sequence B, each number is obtained by adding 3 to the previous number. Complete the table. [1]

Term (x)	1	2	3	4	5
Number (y)	3	6			
(x, y)	(1, 3)	(2, 6)			

- (b) Plot both sets of ordered pairs on the graph at the right and connect the points in each set. Describe what happens to the distance between the two lines as x increases. [3]

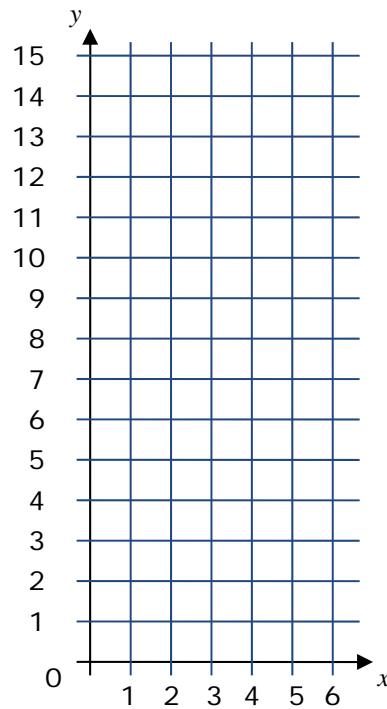

22. Water is flowing from a tap in to a tank. Every minute 25 gallons of water is added to the tank.

(a) Complete this table for the amount of water in the tank. [2]

Time (min)	1	2	3	4	5	6
Amount (gal)	25					

(b) Plot these points in a line graph. [2]

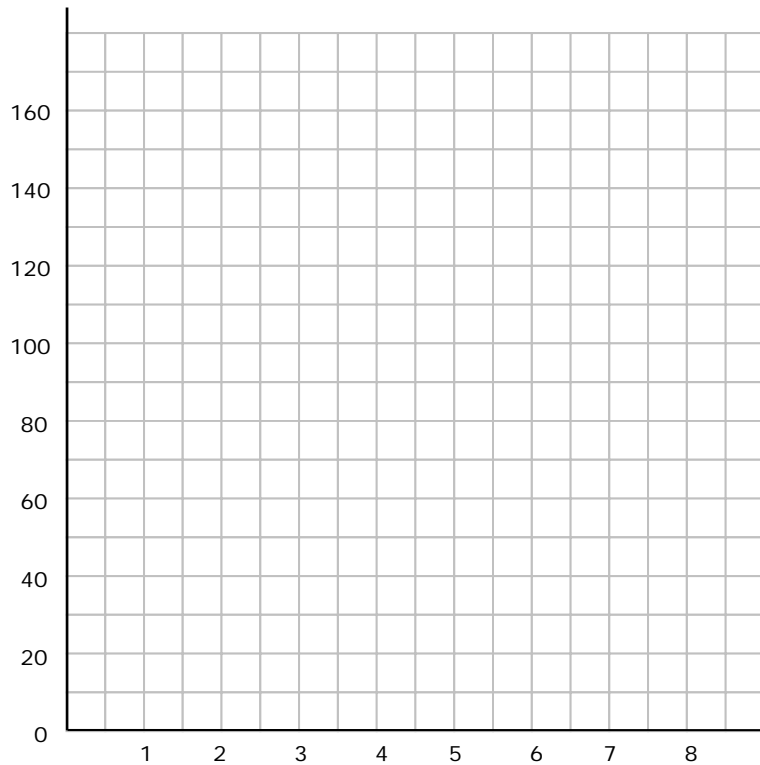

(c) Use the graph to estimate to the nearest tenth of a minute how long it takes until there is 120 gallons in the tank _____ [1]

23. The following figures are not drawn to scale. Find the unknown marked angle in each.

(a) ABC is a straight line. BCD is an equilateral triangle. [2]

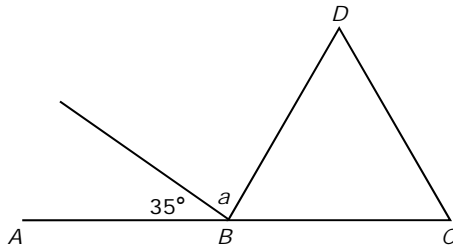

(b) ABCD is a quadrilateral. [2]

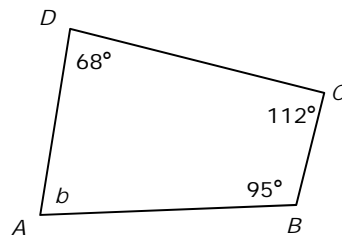

(c) ABCD is a parallelogram. [2]

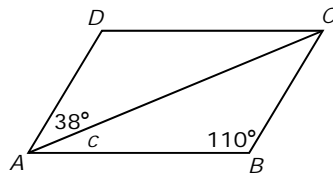

(d) ABC is a straight line. BCDE is a rhombus. [2]

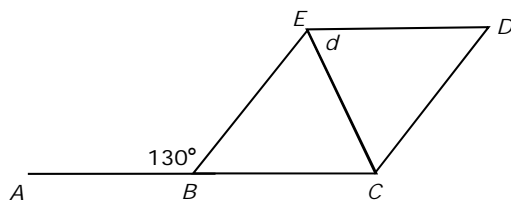

24. Express each as a percentage.	[1]
(a) 0.47	
(b) $\frac{6}{15}$	[1]
(c) 215 out of 500	[1]
25. Express as a decimal and as a fraction in its simplest form.	[2]
85% Decimal: _____ Fraction: _____	
26. John had \$75. He spent \$15 on a book. What percentage of his money does he have left?	[3]
27. The normal price of a camera was \$76. At a sale it was sold at a discount of 15%. What was the selling price of the camera?	[3]

Answer Key

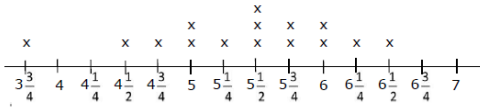
- 0.4
 - 0
 - 0.006
 - $10; 1; \frac{1}{10}; \frac{1}{1,000}$
- >
 - >
 - >
 - =
 - <
 - <
- 40
 - 0.568
 - 320
 - 8
 - 0.7
 - 6,000
- 4 cm
 - 0.035 L
 - 6 lb 4 oz
 - 9 in.
- 800; 731.86
 - 16; 17.739
 - 0.5; 0.625
 - 2,000; 2,249
- 713.57
 - 2.89
- \$4.20
- 27 ft³
- 120 m³
 - 2,375 cm³
- 216 cm³
- 5 cm
- 3.2 liters
- 3750 4-cm cubes
- 9 cm³
- 35.1
- 17
- 1 kg 850 g
- 
 - $2\frac{2}{3}$ lb
 - $\frac{1}{5}$
 - $5\frac{2}{5}$ lb
- A: (4, 9) B: (9, 5)
C: (4, 3) D: (10, 2)
 - Check placement of point.
 - second

20. 42 cm²

21. (a)

x	3	4	5
y	6	8	10
(x, y)	(2, 4)	(4, 8)	(5, 10)

(b)

x	3	4	5
y	9	12	15
(x, y)	(2, 9)	(4, 12)	(5, 15)

- (c) The distance between the points increases by 1 for each increase of 1 in x .

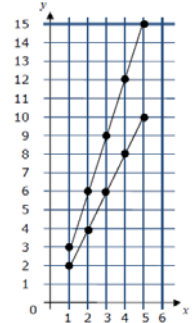

22. (a)

Time (min)	1	2	3	4	5	6
Amount (gal)	25	50	75	100	125	150

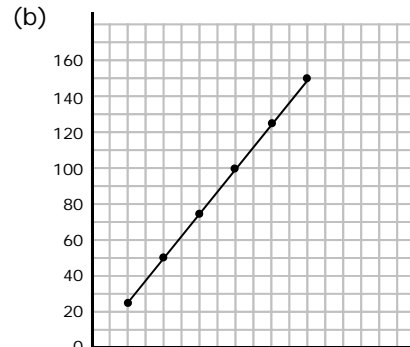

- (c) 4.8 (accept 4.47 or 4.69) ^{7 8}

- 85°
 - 85°
 - 32°
 - 65°
- 47%
 - 40%
 - 43%
- 0.85; $\frac{17}{20}$
- 80%
- \$64.60